



1 Lena owns a café.

(a) One day, Lena records the drinks she sells in one hour.

Tea          Tea          Coffee          Juice          Milkshake          Milkshake          Coffee          Coffee  
 Milkshake      Coffee      Tea          Juice          Tea          Coffee          Tea          Juice  
 Milkshake      Tea          Milkshake      Tea          Coffee          Tea          Milkshake      Coffee

(i) Complete the frequency table.  
 You may use the tally column to help you.

Drink	Tally	Frequency
Coffee		
Juice		
Milkshake		
Tea		
Total		24

[2]

(ii) Draw a bar chart to show this information.  
 Complete the scale on the frequency axis.

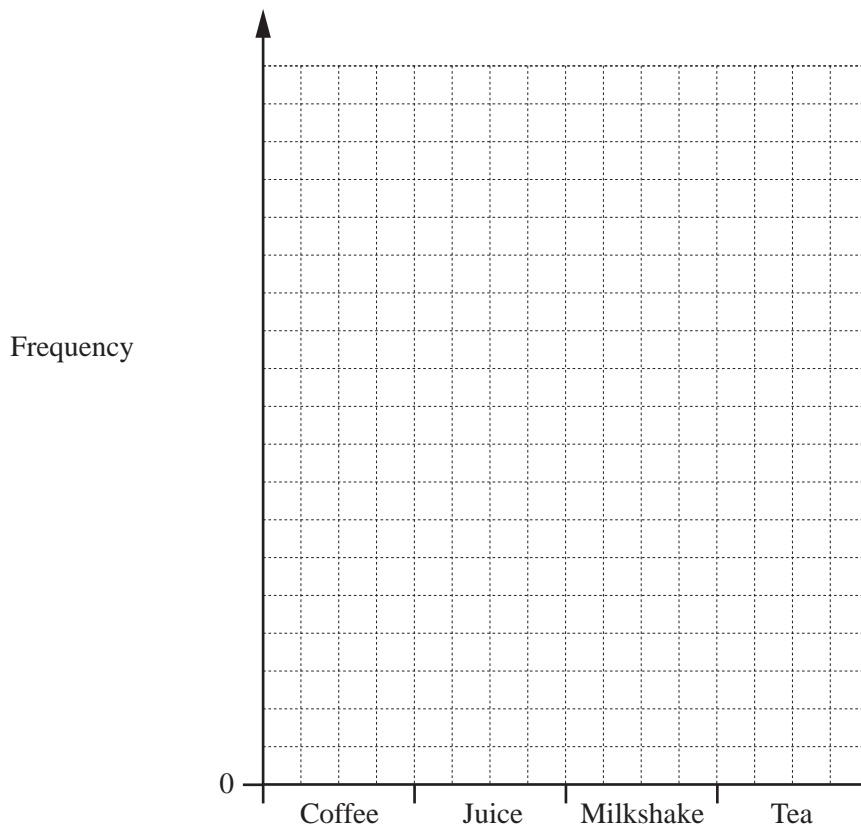

[3]

(b) This table shows the opening hours of the café.

Day	Opening hours
Monday to Thursday	08 30 to 17 00
Friday and Saturday	08 30 to 19 00
Sunday	09 00 to 18 00

(i) Work out the total number of hours the café is open in one week.

..... hours [2]

(ii) Lena is in the café for 40 hours each week.  
Ron is in the café when Lena is not there.

Calculate the percentage of the total opening hours that Ron is in the café each week.

..... % [2]

(c) Saddak buys 3 cups of tea and 2 cookies for \$6.95 .  
A cup of tea costs \$1.75 .

Work out the cost of one cookie.

\$ ..... [2]

(d) The price of a cake is \$2.60 .  
At the end of the day, Lena reduces the price of each cake by 35%.

Calculate the reduced price of a cake.

\$ ..... [2]

- 2 (a) Write down all the factors of 18.

..... [2]

- (b) Write down a prime number between 40 and 50.

..... [1]

- (c) Calculate  $1.09 + \frac{7.85}{6.21 - 4.37}$ .

Give your answer correct to 1 decimal place.

..... [2]

- (d) Find the value of

(i)  $\sqrt{2.89}$ ,

..... [1]

(ii)  $14^3$ ,

..... [1]

(iii)  $4^{-2}$ .

..... [1]

(e) (i)  $126 = 2 \times 3^2 \times k$

Find the value of  $k$ .

$k = \dots\dots\dots$  [1]

(ii) Write 90 as the product of its prime factors.

$\dots\dots\dots$  [2]

(iii) Find the lowest common multiple (LCM) of 90 and 126.

$\dots\dots\dots$  [2]

- 3 (a) The table gives some information about the numbers of visitors at a leisure centre one day.

	Adult	Child	Total
Male		144	240
Female	129		260
Total	225	275	500

- (i) Complete the table. [1]

- (ii) Work out how many more child visitors than adult visitors there are.

..... [1]

- (iii) Write down the fraction of visitors that are adults.  
Give your answer in its lowest terms.

..... [2]

- (iv) Write the ratio number of males : number of females.  
Give your answer in its simplest form.

..... : ..... [2]

- (v) One of these visitors is selected at random.

Find the probability that this visitor is a male child.

..... [1]

- (b) The number of people in each of 150 cars entering the leisure centre car park is recorded. The table shows the results.

Number of people	1	2	3	4	5
Frequency	44	43	30	25	8

- (i) Write down the mode.

..... [1]

- (ii) Calculate the mean.

..... [3]

- (c) In a survey of 50 visitors to the leisure centre, 18 used the gym. One day, 1500 people visited the leisure centre.

Calculate an estimate for the number of people who used the gym on this day.

..... [2]

- 4 (a) (i) Complete the table of values for  $y = x^2 - 5x$ .

$x$	-1	0	1	2	3	4	5	6
$y$			-4	-6	-6	-4	0	

[2]

- (ii) On the grid, draw the graph of  $y = x^2 - 5x$  for  $-1 \leq x \leq 6$ .

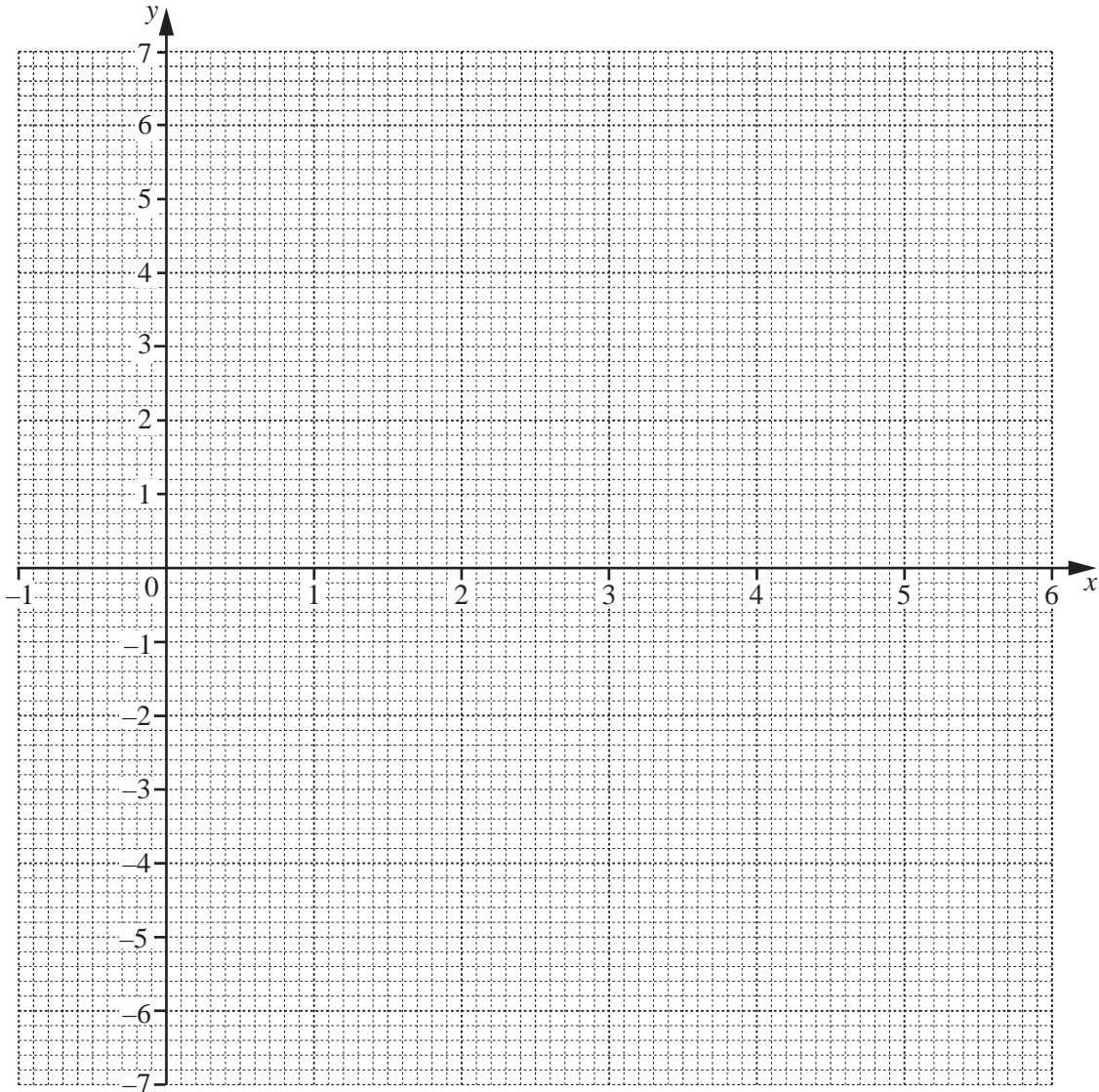

[4]

- (iii) Write down the co-ordinates of the lowest point of your graph.

(....., .....) [1]

- (iv) Use your graph to solve the equation  $x^2 - 5x = 3$ .

$x = \dots\dots\dots$  or  $x = \dots\dots\dots$  [2]



(b)

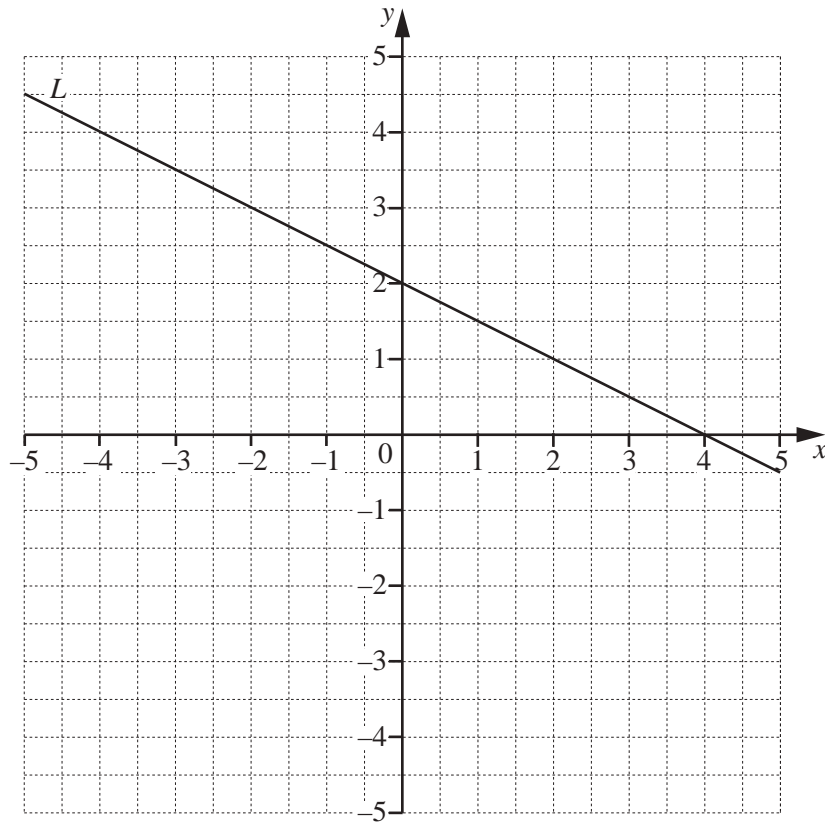

Line  $L$  is drawn on the grid.

- (i) Find the equation of line  $L$  in the form  $y = mx + c$ .

$$y = \dots\dots\dots [3]$$

- (ii) Line  $P$  is parallel to line  $L$  and passes through the point  $(0, -1)$ .

On the grid above, draw line  $P$  for  $-5 \leq x \leq 5$ . [2]

- 5 (a) The scale drawing shows the positions of a lighthouse  $L$  and a ship  $S$ .  
The scale is 1 centimetre represents 5 kilometres.

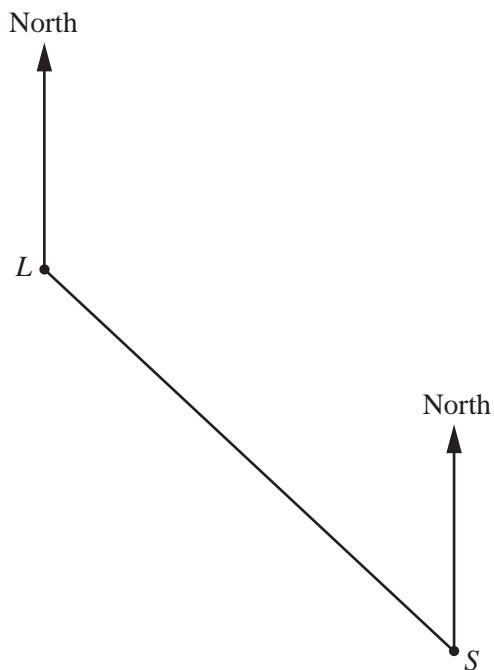

Scale: 1 cm to 5 km

- (i) Work out the actual distance, in kilometres, from  $S$  to  $L$ .

..... km [2]

- (ii) Measure the bearing of  $S$  from  $L$ .

..... [1]

- (iii) Another ship,  $T$ , is 22 km from  $L$  on a bearing of  $210^\circ$ .

Mark and label the position of  $T$  on the scale drawing. [2]

(b) In this part, use a ruler and compasses only and show your construction arcs clearly.

The scale drawing shows the positions of two yachts,  $P$  and  $Q$ .  
The scale is 1 centimetre represents 100 metres.



Scale: 1 cm to 100 m

(i) Construct the locus of points equidistant from  $P$  and  $Q$ . [2]

(ii) Another yacht,  $Y$ , is

- closer to  $P$  than to  $Q$
- and
- less than 700 m from  $Q$ .

On the scale drawing, construct and shade the region where yacht  $Y$  is. [3]

6 (a)

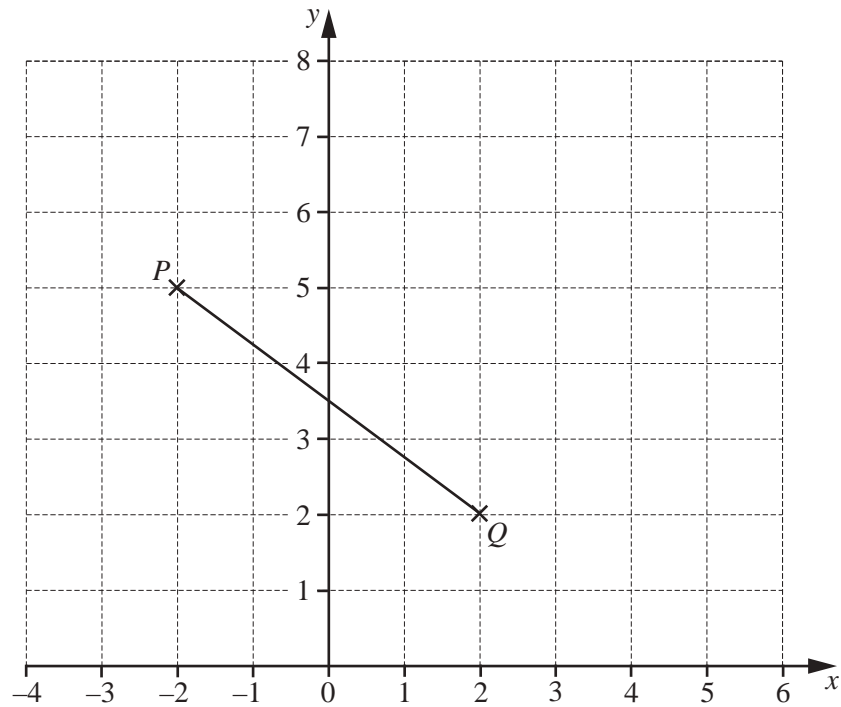

(i) Write down the co-ordinates of point  $P$ .

(....., .....) [1]

(ii) Write down the column vector  $\vec{PQ}$ .

$\vec{PQ} = \begin{pmatrix} \phantom{0} \\ \phantom{0} \end{pmatrix}$  [1]

(iii)  $\vec{QR} = \begin{pmatrix} 3 \\ 2 \end{pmatrix}$

On the grid, plot point  $R$ .

[1]

(iv)  $PQRS$  is a parallelogram.

On the grid, complete the parallelogram  $PQRS$ .  
Write down the co-ordinates of point  $S$ .

(....., .....) [2]

(b)

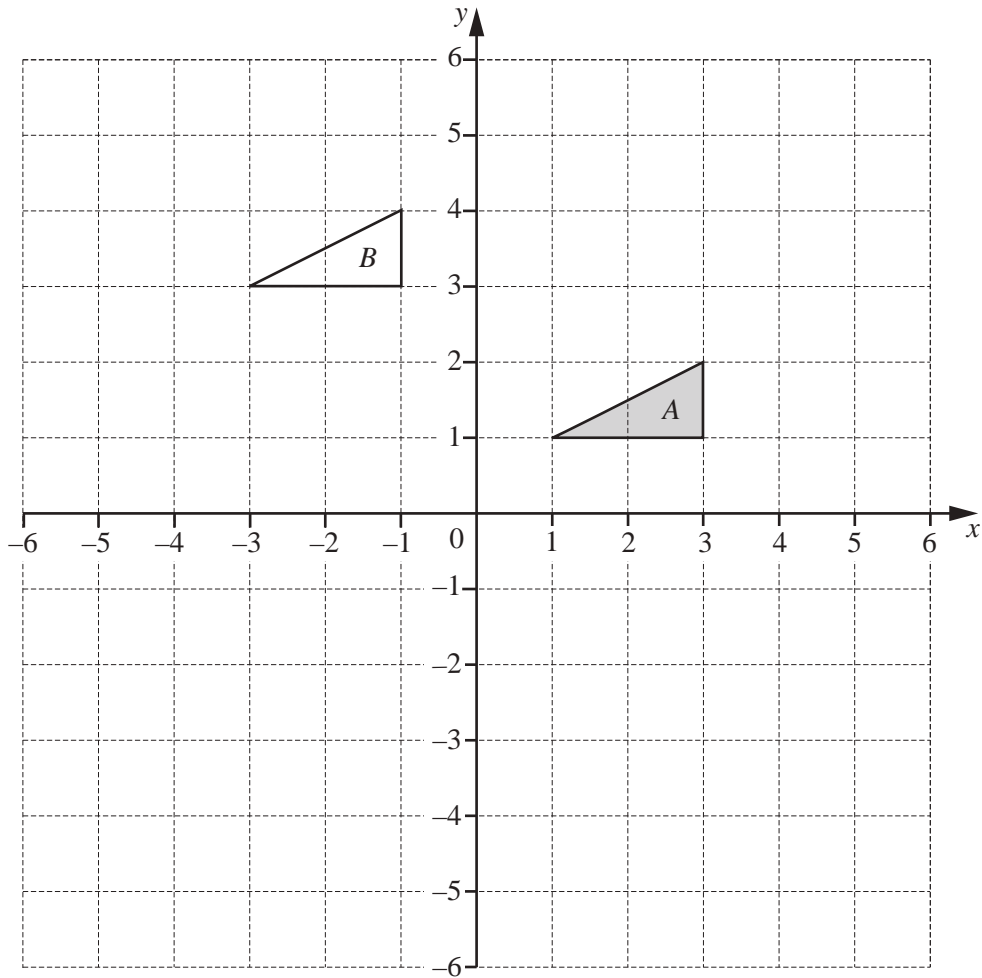

(i) Describe fully the **single** transformation that maps triangle *A* onto triangle *B*.

.....  
 ..... [2]

(ii) On the grid, draw the image of triangle *A* after a reflection in the line  $y = -1$ . [2]

(iii) On the grid, draw the image of triangle *A* after a rotation through  $180^\circ$  about  $(0, 0)$ . [2]

7 Nora makes a birthday cake.

(a) Nora has a packet containing 250 g of cherries.

She uses  $\frac{7}{10}$  of the cherries in the cake.

Find the mass of cherries she has left.

..... g [2]

(b) The cake is made by putting a small cylinder of cake on top of a large cylinder of cake.

The radius of the large cylinder is 15 cm.

The radius of the small cylinder is 8 cm.

The height of each cylinder is 10 cm.

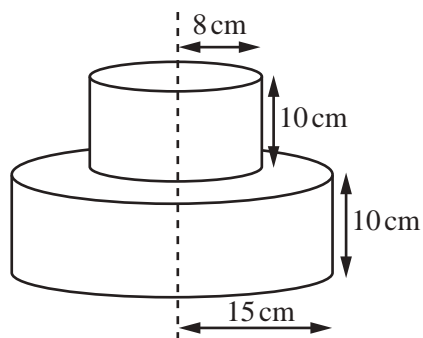

NOT TO SCALE

(i) Calculate the total volume of the cake.

.....cm<sup>3</sup> [3]

(ii) Nora wraps a ribbon around the large cylinder.

The ribbon is 4 cm longer than needed to go all the way around this cylinder.

Calculate the length of this ribbon.

..... cm [3]

(c) The mass,  $m$  grams, of the cake is 1250 g, correct to the nearest 10 g.

Complete this statement about the value of  $m$ .

.....  $\leq m <$  ..... [2]

- 8 (a) Simplify.

$$4c + 2d - c + 6d$$

..... [2]

(b)  $h = 5m - 2n$

Calculate  $h$  when  $m = 4$  and  $n = -6$ .

..... [2]

- (c) Solve.

$$7(x - 3) = 56$$

 $x =$  ..... [2]

- (d) Make
- $t$
- the subject of the formula
- $r = 6t + 7$
- .

 $t =$  ..... [2]

- (e) The diagram shows a triangle.

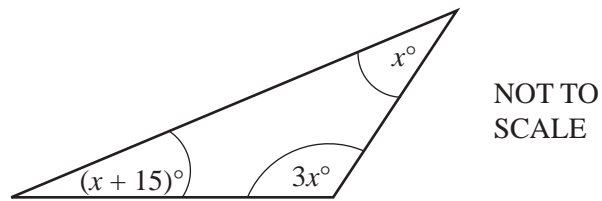
Use the diagram to write down an equation and solve it to find the value of  $x$ . $x =$  ..... [4]**Question 9 is printed on the next page.**

9

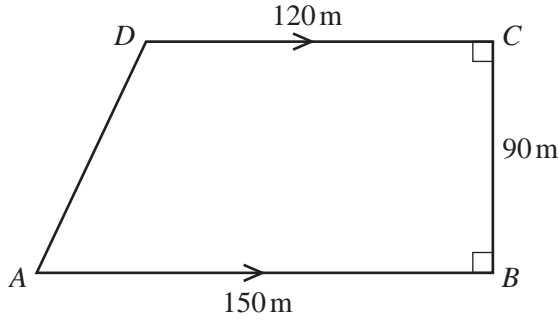

NOT TO SCALE

The diagram shows a field in the shape of a trapezium.

$AB = 150\text{ m}$ ,  $BC = 90\text{ m}$  and  $CD = 120\text{ m}$ .

Angle  $ABC = \text{angle } BCD = 90^\circ$ .

(a) Calculate the area of the field.

.....m<sup>2</sup> [2]

(b) (i) Show that  $AD = 95\text{ m}$ , correct to the nearest metre.

[3]

(ii) A fence is built around the perimeter of the field.  
It costs \$48 to build each 5-metre section of the fence.

Calculate the cost of building this fence.

\$ ..... [3]

Permission to reproduce items where third-party owned material protected by copyright is included has been sought and cleared where possible. Every reasonable effort has been made by the publisher (UCLES) to trace copyright holders, but if any items requiring clearance have unwittingly been included, the publisher will be pleased to make amends at the earliest possible opportunity.

To avoid the issue of disclosure of answer-related information to candidates, all copyright acknowledgements are reproduced online in the Cambridge International Examinations Copyright Acknowledgements Booklet. This is produced for each series of examinations and is freely available to download at [www.cie.org.uk](http://www.cie.org.uk) after the live examination series.

Cambridge International Examinations is part of the Cambridge Assessment Group. Cambridge Assessment is the brand name of University of Cambridge Local Examinations Syndicate (UCLES), which is itself a department of the University of Cambridge.